

# XD

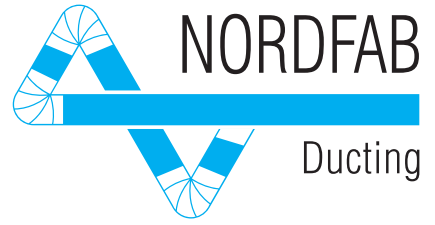

## 12 and 14 Gauge Ducting Product Selection Catalog



# Nordfab Ducting

## New Heavier Gauge Ducting

Nordfab is introducing XD Ducting, our line of ducting constructed from galvanized steel in 12 and 14 gauge. Ducting in 14ga is available with our popular QF rolled ends for clamp-together installation in sizes from 8" to 24" diameter or in sizes from 8" to 40" with Angle Flanged ends. Ducting in 12ga is available in sizes from 8" to 40" and provided with Angle Flanged ends.

Nordfab ductwork is ideal for most dust, mist and fume collection applications.



## The World's Fastest Ducting

Nordfab's Quick-Fit™ (QF) is "The World's Fastest Ducting" in every aspect of your dust collection installation. Our ducting with QF rolled ends clamps together in seconds without welds, bolts, screws, flanges, special tools, precise measurements or specialized skills. Whenever your application allows clamp-together duct, QF cuts installation time – and duct-related downtime – by more than 45% over traditional ductwork.

This product catalog contains information for ordering Nordfab XD ducting in galvanized steel in diameters from 8" to 40". If you are in need of custom fittings for specialized applications, ask your salesperson for availability. Visit [www.nordfab-us.com](http://www.nordfab-us.com) for Technical Data sheets and additional product information.



## Fast, Friendly and Reliable

When you contact Nordfab, you will find that from the time you first need design or quotation assistance, through delivery and installation, to after-sales service / replacement parts, Nordfab employees and products are "Fast, Friendly, and Reliable".

Our nationwide distribution network understands the urgency of your requests and has the tools and training to design and quote a system very quickly.

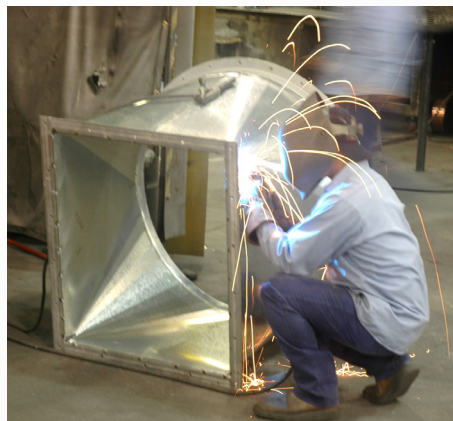

## Enhanced Production Capabilities

Nordfab currently owns and operates an 80,000 square-foot office and manufacturing facility and a 30,000 square-foot XD manufacturing facility in Thomasville, North Carolina. More than 140 production, sales, and customer support employees work at our facilities.

No direct competitor in the industry matches Nordfab's investment in qualified employees, R&D or production technology. Nordfab is a global manufacturer with facilities in Europe (Scandinavia and the United Kingdom) and Asia as well as the USA.

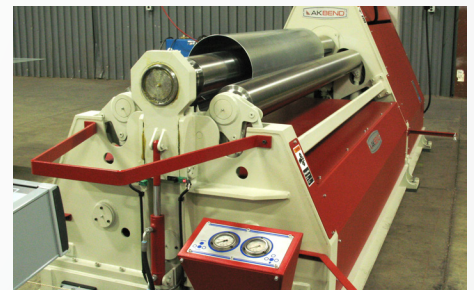

## Nordfab Quality Standards

Nordfab is ISO 9001:2008 and ISO 14001:2004 registered, ensuring our dependability, quality, service, delivery, and mini-

REGISTERED  
**ISO**  
9001:2008  
14001:2004

imum impact on the environment. Nordfab is also 6S compliant, continuously improving plant processes and organization. In our continuing effort to ensure quality, our XD product fabricators inspect welds to AWS standards.

# Nordfab Part Numbers & Product Groupings

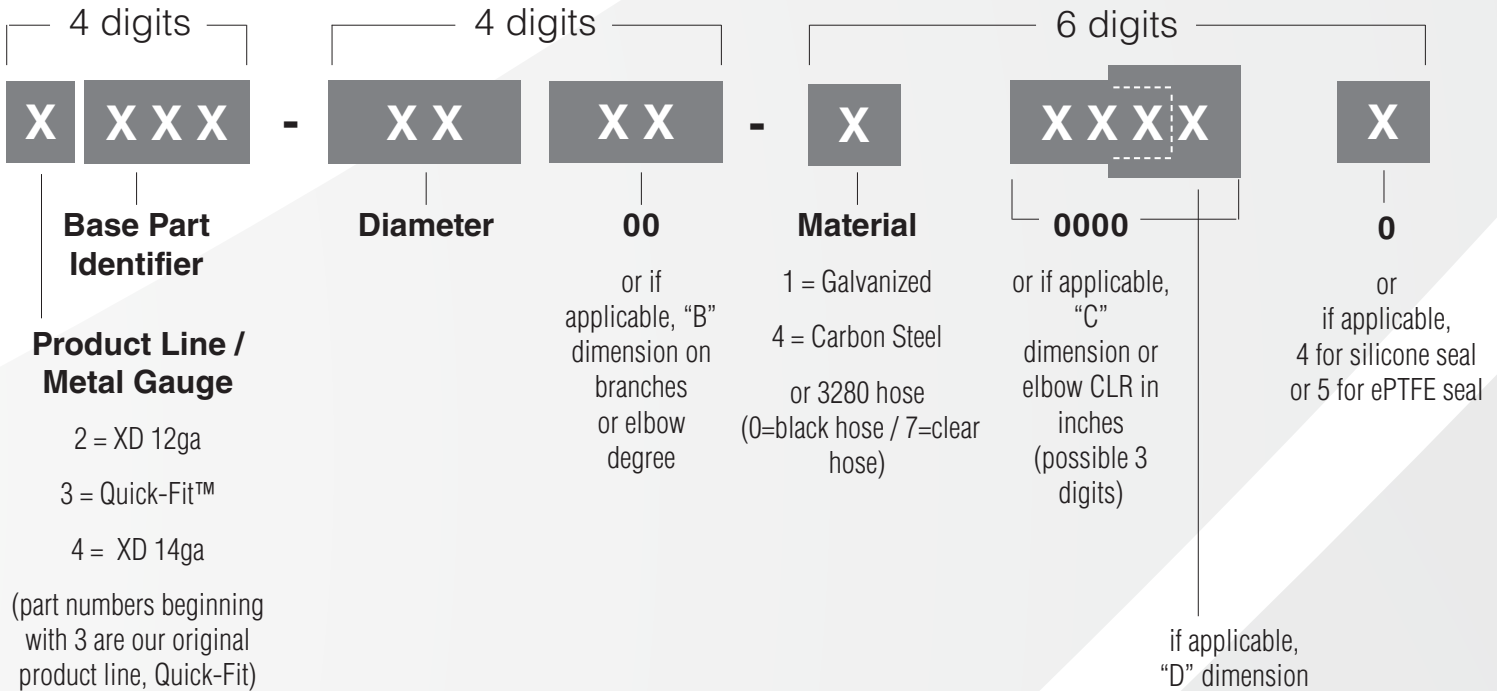

## Examples:

- 4200-1000-100000 = 14ga Pipe: 10" diameter QF galvanized
- 2200-1200-100000 = 12ga Pipe: 12" diameter flanged galvanized
- 2210-1090-115000 = 12ga Elbow: 10" diameter 90° galvanized, 1.5 CLR (15 = CLR x dia.)
- 4220-1008-106000 = 14ga Branch: A=10", B=8", C=6" galvanized
- 3260-1000-100004 = QF Clamp: 10" diameter galvanized with silicone seal

## End Types (See illustrated examples of End Types on page 15)

**QF:** Quick-Fit™ rolled ends for quick connection to other QF components using the QF Clamp.

**ANGFL:** Industry-standard Angle Ring.

Nordfab standard is Angle Flange (ANGFL) attached loosely and retained in place using a 1/2" vanstone lip. Upon customer request, the flange can be solid welded to product or provided loose (separate) with a NOFIT end on product.

**FFL** - Flat Flange. Provided when custom flange is required (for options such as custom hole pattern). Same connections as ANGFL.

**RAWFLEX** - Raised dimple to retain flexible hose.

**NOFIT** - No Fitting. A raw end with dimension based on product size.

**RAWOD** - Raw end without fitting. End dimension based on customer specified Outside Diameter.

**RAWID** - Raw end without fitting. End dimension based on customer specified Inside Diameter.



# Table of Contents

DESCRIPTION	PART #	CENTER LINE RADIUS	PAGE	DESCRIPTION	PART #	PAGE
Angle Flange	3261		6	Flanged Pipe	X201	5
Angle Flange Adapter	4250		6	Hose Adapter	X282	11
Angle Flange Gasket	3263		6	Hose Clamp	3285	14
Blast Gate Automatic NFES	X245		13	In-Cut	X223	10
Blast Gate Manual	4240		13	Jet Cap	X258	17
Branch	X220		9	Machine Adapter	4249	11
Bridge Clamp (Hose)	3288		14	No-Loss Stackhead	X204	17
Canopy Hood	X270		18	Pipe	X200	5
Clamp w/ Pin - Nitrile Seal	3260		5	Reducer	X222	12
Clamp w/ Pin - Silicone Seal	3260		5	Reed Switch Assembly 1.06	3245-0000-RSW106	13
Clamp w/ Pin - ePTFE Seal	3260		5	Reed Switch Assembly 2.50	3203-0000-RSW250	16
Custom Manifold	-		12	Rigid Flex Steel Hose	3281	15
◇ Diverter Valve Automatic	X236		16	Rubber Hose	3280	14
◇ Diverter Valve Manual	X235		16	Static Dissipative Urethane Hose	3279	14
Double Branch	X226		10	Transition Rectangular to Round	X225	12
Drawing Service	DS/MC		20	Ultra Flex Steel Hose	3283	15
Elbow	X210	90° 1.5 CLR	7	Y-Branch	X221	9
		60° 1.5 CLR	7	Air Volume Chart		22
		45° 1.5 CLR	8	Branch Styles		19
		30° 1.5 CLR	8	Conditions of Sale		23
Elbow Flanged	X211	90° 1.5 CLR	7	Drawing Service		20
		60° 1.5 CLR	7	Flex Hose Styles		15
		45° 1.5 CLR	8	Reducer Styles		19
		30° 1.5 CLR	8	Sizing a Pipe System		22
End Cap / End Plate	X151		11	Take-Off Sheet		21
				Transition Styles		20

**See our QF product line catalog for additional ducting components in lighter gauges. Contact your salesperson about pricing and availability if you don't see 12 or 14 gauge items that you require.**

## Ductwork Product Groups

This price catalog is organized into the following product groups:

[Pipe and Clamps](#), pages 5 - 6

[Elbows](#), page 7 - 8

[Branches](#), pages 9 - 10

[Adapters](#), pages 11 - 12

[Blast Gates](#), page 13

[Hoses & Hose Clamps](#), pages 14 - 15

[Diverter Valves](#), page 16

[Accessories](#), pages 17

[Hoods](#), page 18

**Catalog and prices are subject to change without notice  
Product photographs reference only  
XD Ducting General Conditions of Sale apply**





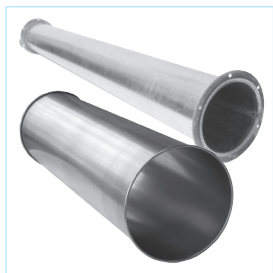

- Plasma welded, painted seam (section of seam shown at right).
- Nominal 5' length.

### XD Duct Pipe

Ø in	XD-QF Pipe, 14ga 4200-XX00-100000	XD-ANGFL Pipe, 14ga 4201-XX00-100000	XD-ANGFL Pipe, 12ga 2201-XX00-100000
8	•	•	•
9	•	•	•
10	•	•	•
11	•	•	•
12	•	•	•
13	•	•	•
14	•	•	•
15	•	•	•
16	•	•	•
17	•	•	•
18	•	•	•
20	•	•	•
22	•	•	•
24	•	•	•
26		•	•
28		•	•
30		•	•
32		•	•
34		•	•
36		•	•
38		•	•
40		•	•

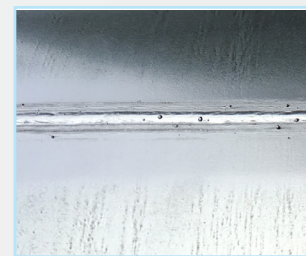

Above: Closeup of section of plasma welded pipe seam.

### Custom Length Cut Pipe Available



- Clamps come standard from factory with Nitrile seals. Silicone or ePTFE seals are optional for an upcharge - specify when ordering. Clamps also may be ordered optionally without seals.
- 3" to 6" Clamps: Small bridge pin with 3/8" wide seal supplied from factory.
- 7" to 11" Clamps: Large bridge pin with 1/2" wide seal supplied from factory.
- 12" to 18" Clamps: Large bridge pin with 5/8" wide seal supplied from factory.
- Nitrile and Silicone seals stocked in rolls of 50'. ePTFE seals stocked in rolls of 100'.

### Quick-Fit™ Clamp

Ø in	Galvanized Clamps with Nitrile Seals 3260-XX00-100900	Galvanized Clamps with Silicone Seals 3260-XX00-100904	Galvanized Clamps with ePTFE Seals 3260-XXXX-100905
8	•	•	•
9	•	•	•
10	•	•	•
11	•	•	•
12	•	•	•
13	•	•	•
14	•	•	•
15	•	•	•
16	•	•	•
17	•	•	•
18	•	•	•
20	•	•	•
22	•	•	•
24	•	•	•

#### ADDITIONAL SEALS

Ø in	Nitrile Part No.	Silicone Part No.	ePTFE Part No.
3 - 6	3260-0375-SP3000	3260-0375-HT3000	3260-0375-SG3000
7 - 11	3260-0500-SP4000	3260-0500-HT4000	3260-0500-SG4000
12 - 18	3260-0650-SP5000	3260-0650-HT5000	3260-0650-SG5000

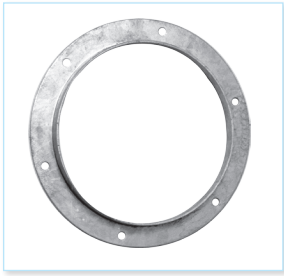

- Industry standard Angle Flange

NOTE: Custom drill patterns available in Flat Flanges. ANSI Flange patterns are charged double the standard. Call for pricing on other options.

### Angle Flange

Ø in	Angle Flange 3261-XX00-100000
3	•
4	•
5	•
6	•
7	•
8	•
9	•
10	•
11	•
12	•
13	•
14	•
15	•
16	•
17	•
18	•
19	•
20	•
21	•
22	•
23	•
24	•
25	•
26	•
27	•
28	•
29	•
30	•
31	•
32	•
33	•
34	•
35	•
36	•
37	•
38	•
39	•
40	•

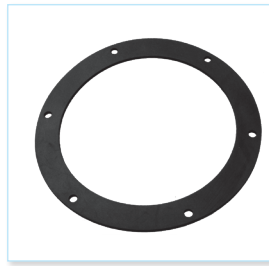

- Black nitrile standard, 60 durometer. Temp range -20°F to 170°F.
- Red silicone optional, 50 durometer. Temp range -65°F to 450°F.
- Nitrile material is conductive.
- One gasket per joint.

### Angle Flange Gasket

Ø in	Nitrile 3263-XX00-000000	Silicone 3263-XX00-000005
3	•	•
4	•	•
5	•	•
6	•	•
7	•	•
8	•	•
9	•	•
10	•	•
11	•	•
12	•	•
13	•	•
14	•	•
15	•	•
16	•	•
17	•	•
18	•	•
19	•	•
20	•	•
21	•	•
22	•	•
23	•	•
24	•	•
25	•	•
26	•	•
27	•	•
28	•	•
29	•	•
30	•	•
31	•	•
32	•	•
33	•	•
34	•	•
35	•	•
36	•	•
37	•	•
38	•	•
39	•	•
40	•	•

\* Silicone Flange 5 - 7 days lead time



- Adapts QF to flanged duct.
- Angle Flange standard. Specify if Flat Flange (FFL) required. If Flat Flange, specify hole pattern. (Cost same as Angle Flange). If no hole pattern drawing provided, Flat Flange will be blank.

### XD Angle Flange Adapter

Ø in	Angle Flange Adapter, 14ga 4250-XX00-100000
8	•
9	•
10	•
11	•
12	•
13	•
14	•
15	•
16	•
17	•
18	•



- Elbows are constructed of butt-welded gores.
- Other CLR's available upon request.
- Interior buffing available with upcharge.
- Welded flanges will be clocked at the centerline as standard.

### XD Elbow

Ø in	XD-QF Elbow, 14ga 4210-XXXX-1XX000	XD-ANGFL Elbow, 14ga 4211-XXXX-1XX000	XD-ANGFL Elbow, 12ga 2211-XXXX-1XX000
<b>90 Degree</b>			
8	•	•	•
9	•	•	•
10	•	•	•
11	•	•	•
12	•	•	•
13	•	•	•
14	•	•	•
15	•	•	•
16	•	•	•
17	•	•	•
18	•	•	•
20	•	•	•
22	•	•	•
24	•	•	•
26		•	•
28		•	•
30		•	•
32		•	•
34		•	•
36		•	•
38		•	•
40		•	•
<b>60 degree</b>			
8	•	•	•
9	•	•	•
10	•	•	•
11	•	•	•
12	•	•	•
13	•	•	•
14	•	•	•
15	•	•	•
16	•	•	•
17	•	•	•
18	•	•	•
20	•	•	•
22	•	•	•
24	•	•	•
26		•	•
28		•	•
30		•	•
32		•	•
34		•	•
36		•	•
38		•	•
40		•	•

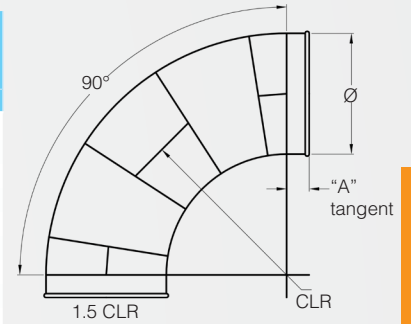

ELBOWS



- Elbows are constructed of butt-welded gores.
- Other CLR's available upon request.
- Interior buffing available with upcharge.
- Welded flanges will be clocked at the centerline as standard.

**XD Elbow**

Ø in	XD-QF Elbow, 14ga 4210-XXXX-1XX000	XD-ANGFL Elbow, 14ga 4211-XXXX-1XX000	XD-ANGFL Elbow, 12ga 2211-XXXX-1XX000
<b>45 Degree</b>			
8	•	•	•
9	•	•	•
10	•	•	•
11	•	•	•
12	•	•	•
13	•	•	•
14	•	•	•
15	•	•	•
16	•	•	•
17	•	•	•
18	•	•	•
20	•	•	•
22	•	•	•
24	•	•	•
26		•	•
28		•	•
30		•	•
32		•	•
34		•	•
36		•	•
38		•	•
40		•	•
<b>30 degree</b>			
8	•	•	•
9	•	•	•
10	•	•	•
11	•	•	•
12	•	•	•
13	•	•	•
14	•	•	•
15	•	•	•
16	•	•	•
17	•	•	•
18	•	•	•
20	•	•	•
22	•	•	•
24	•	•	•
26		•	•
28		•	•
30		•	•
32		•	•
34		•	•
36		•	•
38		•	•
40		•	•

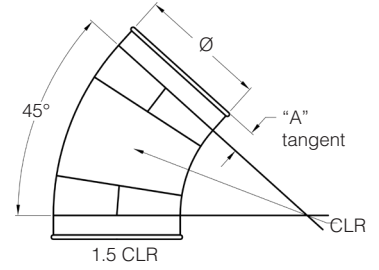





### XD Branch

Ø in	XD-QF Branch, 14ga 4220-XXXX-1XX000	XD-ANGFL Branch, 14ga 4220-XXXX-1XX000	XD-ANGFL Branch, 12ga 2220-XXXX-1XX000
8	•	•	•
9	•	•	•
10	•	•	•
11	•	•	•
12	•	•	•
13	•	•	•
14	•	•	•
15	•	•	•
16	•	•	•
17	•	•	•
18	•	•	•
20	•	•	•
22	•	•	•
24	•	•	•
26	•	•	•
28	•	•	•
30	•	•	•
32	•	•	•
34	•	•	•
36	•	•	•
38	•	•	•
40	•	•	•

- Standard 30° Optional 45°.
- When ordering specify A, B, C.
- A-B ≥ B-C
- Use formula above to determine if a reducer is needed at "C".
- Vanstone end with rotational flanges standard. If welded flanges requested, clocking must be specified.

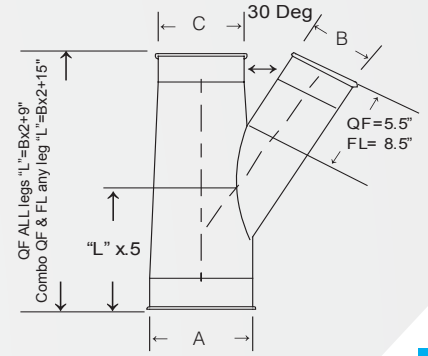

Any Branch with B, C, or D end smaller than 8" will be hybrid. Smaller section will be a lighter gauge.

BRANCHES



### XD Y-Branch (Traditional Pant Leg Design)

Ø in	XD-QF Y-Branch, 14ga 4221-XXXX-1XX000	XD-ANGFL Y-Branch, 14ga 4221-XXXX-1XX000	XD-ANGFL Y-Branch, 12ga 2221-XXXX-1XX000
8	•	•	•
9	•	•	•
10	•	•	•
11	•	•	•
12	•	•	•
13	•	•	•
14	•	•	•
15	•	•	•
16	•	•	•
17	•	•	•
18	•	•	•
20	•	•	•
22	•	•	•
24	•	•	•
26	•	•	•
28	•	•	•
30	•	•	•
32	•	•	•
34	•	•	•
36	•	•	•
38	•	•	•
40	•	•	•

- Standard 60° Optional 90°.
- When ordering specify A, B, D.
- Both B & D each must be at least 50% of A. With B or D being at least 80% of the opposite leg.
- Leg length = 1/2 greater of B or D
- Vanstone end with rotational flanges standard. If welded flanges requested, clocking must be specified.

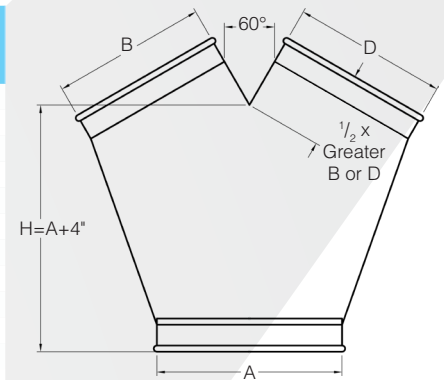



- When ordering, specify A,B,C,D.
- $(A-B) \geq (B-C)$  and  $(B) \geq (D)$
- Reducer at "B" or "D" may be required. Use formula above to determine.
- Standard 30° Optional 45°
- Vanstone end with rotational flanges standard. If welded flanges requested, clocking must be specified.

### XD Double Branch

Ø in	XD-QF Double Branch, 14ga 4226-XXXX-1XXXX0	XD-ANGFL Double Branch, 14ga 4226-XXXX-1XXXX0	XD-ANGFL Double Branch, 12ga 2226-XXXX-1XXXX0
8	•	•	•
9	•	•	•
10	•	•	•
11	•	•	•
12	•	•	•
13	•	•	•
14	•	•	•
15	•	•	•
16	•	•	•
17	•	•	•
18	•	•	•
20	•	•	•
22	•	•	•
24	•	•	•
26		•	•
28		•	•
30		•	•
32		•	•
34		•	•
36		•	•
38		•	•
40		•	•

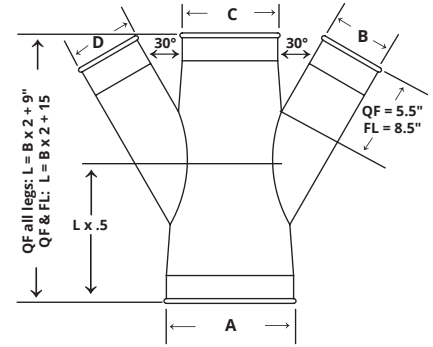

Any Branch with B, C, or D smaller than 8" will be hybrid. Smaller section will be a lighter gauge.



- In-cut used to cut into existing lines.
- Specify A and B diameter and end treatment. Standard end is QF.
- Standard 30° Optional 45°.
- Vanstone end with rotational flanges standard. If welded flanges requested, clocking must be specified.

### XD In-Cut

Ø in	XD-QF In-Cut 14ga 4223-XXXX-100000	XD-ANGFL In-Cut, 14ga 4223-XXXX-100000	XD-ANGFL In-Cut, 12ga 2223-XXXX-100000
8	•	•	•
9	•	•	•
10	•	•	•
11	•	•	•
12	•	•	•
13	•	•	•
14	•	•	•
15	•	•	•
16	•	•	•
17	•	•	•
18	•	•	•
20	•	•	•
22	•	•	•
24	•	•	•
26		•	•
28		•	•
30		•	•
32		•	•
34		•	•
36		•	•
38		•	•
40		•	•

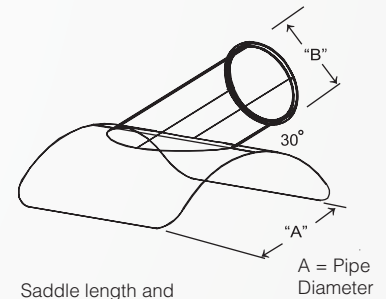

Saddle length and width = 3" all directions from Branch Tube (B).

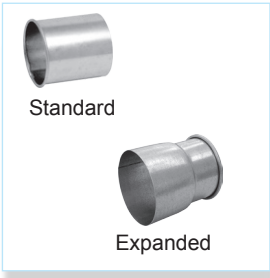

### XD Machine Adapter

Ø in	XD-QF Machine Adapter, 14ga 4249-XX00-100000	XD-ANGFL Machine Adapter, 14ga 4249-XX00-100000
8	•	•
9	•	•
10	•	•
11	•	•
12	•	•
13	•	•
14	•	•
15	•	•
16	•	•
17	•	•
18	•	•
20	•	•
22	•	•
24	•	•
26		•
28		•
30		•
32		•
34		•
36		•
38		•
40		•

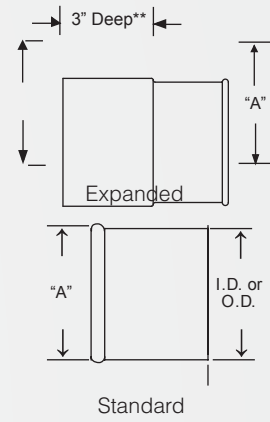

Adapters can only be expanded up to .3" above the nominal diameter size ("A" dimension). Expansions larger than .3" should be ordered as a reducer.

- Standard end styles are QF to NOFIT.
- If Expanded, specify desired ID or OD of non QF end.
- Specify if different end style required. Options are: flanged (ANGFL or FFL) and raw (RAWID or RAWOD).
- Must be within maximum opened dimension (.3"), or will be priced as reducer.

ADAPTERS

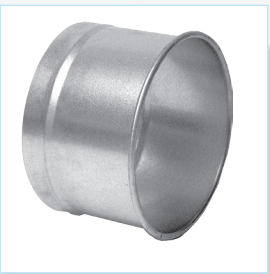

### XD Hose Adapter

Ø in	XD-QF Hose Adapter, 14ga 4282-XX00-100000	XD-ANGFL Hose Adapter, 14ga 4282-XX00-100000	XD-ANGFL Hose Adapter, 12ga 2282-XX00-100000
8	•	•	•
9	•	•	•
10	•	•	•
11	•	•	•
12	•	•	•
13	•	•	•
14	•	•	•
15	•	•	•
17	•	•	•
18	•	•	•
20	•	•	•
22	•	•	•
24	•	•	•
26		•	•
28		•	•
30		•	•
32		•	•
34		•	•
36		•	•
38		•	•
40		•	•

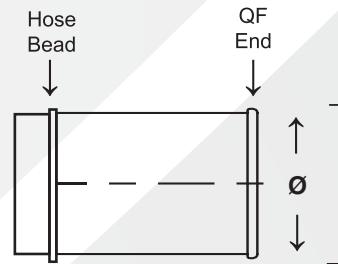

- Used to connect to rubber hose.
- Will not work with metal flex hose.

### XD End Cap / End Plate

Ø in	XD-QF End Cap, 14ga 4151-XX00-100000	XD-ANGFL End Plate, 14ga 4151-XX00-100000	XD-ANGFL End Plate, 12ga 2151-XX00-100000
8	•	•	•
9	•	•	•
10	•	•	•
11	•	•	•
12	•	•	•
13	•	•	•
14	•	•	•
15	•	•	•
16	•	•	•
17	•	•	•
18	•	•	•
20	•	•	•
22	•	•	•
24	•	•	•
26		•	•
28		•	•
30		•	•
32		•	•
34		•	•
36		•	•
38		•	•
40		•	•

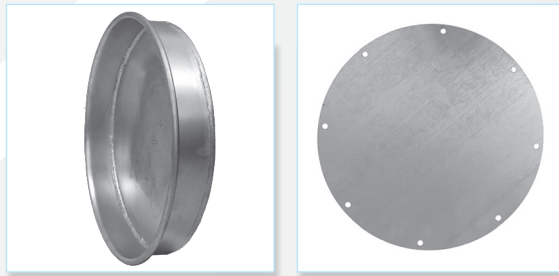

- End Caps enable users to close off taps for future use.
- Flanged End Caps will be a flat plate and angle ring.



- When ordering specify A,B.
- Specify reducer end style.
- X & Y are standard 2" long nominal.
- QF length (L)= A-B+6", 7" min.
- FL length (L)= A-B+8", 9" min.

### XD Reducer

Ø in	XD-QF Reducer, 14ga 4222-XXXX-100000	XD-ANGFL Reducer, 14ga 4222-XXXX-100000	XD-ANGFL Reducer, 12ga 2222-XXXX-100000
8	•	•	•
9	•	•	•
10	•	•	•
11	•	•	•
12	•	•	•
13	•	•	•
14	•	•	•
15	•	•	•
16	•	•	•
17	•	•	•
18	•	•	•
20	•	•	•
22	•	•	•
24	•	•	•
26	•	•	•
28	•	•	•
30	•	•	•
32	•	•	•
34	•	•	•
36	•	•	•
38	•	•	•
40	•	•	•

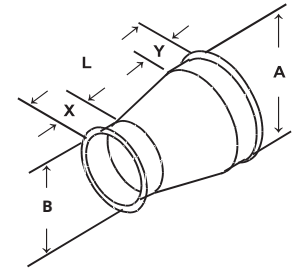

Any Reducer with B end smaller than 8" will be hybrid. Smaller section will be a lighter gauge.

ADAPTERS

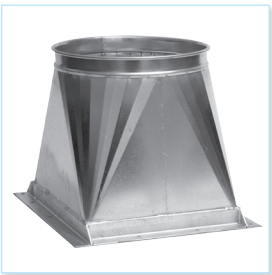

\*NOTE: Minimum L = B x .75. If less, square to square transition will be provided. 7" minimum L allowable for Sq to Rd and 4" L minimum allowable for Sq to Sq.

### XD Transition Rectangular to Round

Ø in	XD-QF Transition, 14ga 4225-XXXX-1XX000	XD-ANGFL Transition, 14ga 4225-XXXX-1XX000	XD-ANGFL Transition, 12ga 2225-XXXX-1XX000
8	•	•	•
9	•	•	•
10	•	•	•
11	•	•	•
12	•	•	•
13	•	•	•
14	•	•	•
15	•	•	•
16	•	•	•
17	•	•	•
18	•	•	•
20	•	•	•
22	•	•	•
24	•	•	•
26	•	•	•
28	•	•	•
30	•	•	•
32	•	•	•
34	•	•	•
36	•	•	•
38	•	•	•
40	•	•	•

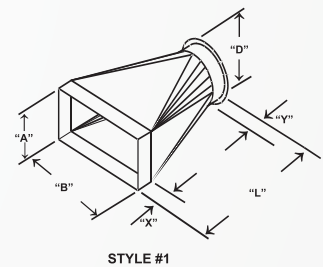

STYLE #1

X=2, Y=2

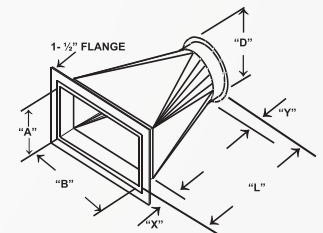

STYLE #2

(flange additional cost)

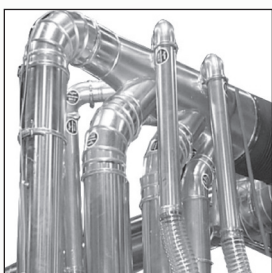

### Custom Manifold

Custom manifolds are available. Contact our sales office for your particular needs.

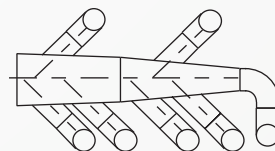



- Manually operated blast gate.

### XD Blast Gate Manual

Ø in	XD-QF Manual Blast Gate, 14ga 4240-XX00-100000	XD-ANGFL Manual Blast Gate, 14ga 4240-XX00-100000
8	•	•
9	•	•
10	•	•
12	•	•
14	•	•
16	•	•
18	•	•
20	•	•
22	•	•
24	•	•
26		•
28		•
30		•
32		•
34		•
36		•
38		•
40		•

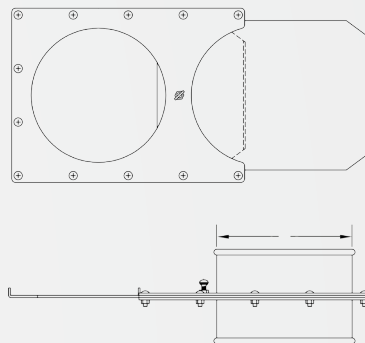

### XD Blast Gate NFES Automatic

Ø in	XD-QF Auto Blast Gate, 14ga 4245-XX00-100000	XD-ANGFL Auto Blast Gate, 14ga 4245-XX00-100000	XD-ANGFL Auto Blast Gate, 12ga 2245-XX00-100000
8	•	•	
9	•	•	•
10	•	•	•
12	•	•	•
14	•	•	•
16	•	•	•
18	•	•	•
20	•	•	•
22	•	•	•



- Automatic energy saving blast gates operated by double-acting compressed air cylinders. Cylinders are controlled by electrically-connected solenoid to machines or remote switch. Gates are constructed of galvanized metal and a special sealing device that reduces air loss and friction in operation. 120V control circuit and 75psi minimum air pressure. Optional 24V DC or AC control circuit available.

• APPLICATION: Gates are used as energy saving devices for industrial dust extraction where extraction is not always needed and where manual control needs to be eliminated.

- Single cylinder: 8". Double cylinder 9" to 22".

- All auto blast gates have cylinders with metal body and steel rod. Solenoid has plastic housing.

All cylinders are magnetic.

BLAST GATES

### Reed Switch Assembly 1.06

**PART NO.**  
3245-0000-RSW106



- Optional position (open/closed) sensing switch with indicator light.
- Assembly includes two switches, one indicating open position and one indicating closed position.
- Applies to both styles of automatic Blast Gate.



- Black thermoplastic flexible rubber hose reinforced with spring steel wire helix.
- Order hose clamps separately.
- 3" - 12" is sold in 5' increments up to 50' maximum.
- 14" - 24" sold in 5' increments up to 25' maximum .
- Use #X282 Hose Adapter with this hose.



- Clear PVC flexible rubber hose reinforced with spring steel wire helix, manufactured with FDA acceptable materials. For non-abrasive material applications.
- Order hose clamps separately.
- 3" - 12" is sold in 5' increments up to 50' maximum.
- 14" - 16" sold in 5' increments up to 25' maximum.
- Inquire for pricing on 18" and larger, special order with a 25' minimum purchase.
- Use #X282 Hose Adapter with this hose.

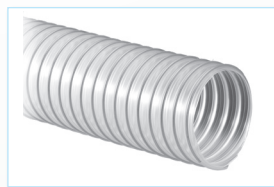

- Medium weight clear static dissipative polyurethane hose reinforced with bronze coated spring steel wire helix, manufactured with FDA acceptable materials.
- Great abrasion resistance & high tear strength as well as superior chemical resistance, excellent flexibility, and tolerance for applications with wide temperature ranges.
- Order hose clamps separately.

### Rubber Hose, Black

Ø in.	Part No.
1.5	3280-1500-000000
2	3280-0200-000000
2.5	3280-2500-000000
3	3280-0300-000000
3.5	3280-3500-000000
4	3280-0400-000000
5	3280-0500-000000
5.5	3280-5500-000000
6	3280-0600-000000
7	3280-0700-000000
8	3280-0800-000000
9	3280-0900-000000
10	3280-1000-000000
12	3280-1200-000000
14	3280-1400-000000
16	3280-1600-000000
18	3280-1800-000000
20	3280-2000-000000
22	3280-2200-000000
24	3280-2400-000000

### Rubber Hose, Clear

Ø in.	Part No.
1	3280-0100-700000
1.5	3280-1500-700000
2	3280-0200-700000
2.5	3280-2500-700000
3	3280-0300-700000
4	3280-0400-700000
5	3280-0500-700000
5.5	3280-5500-700000
6	3280-0600-700000
7	3280-0700-700000
8	3280-0800-700000
9	3280-0900-700000
10	3280-1000-700000
12	3280-1200-700000
14	3280-1400-700000
16	3280-1600-700000
18	3280-1800-700000
20	3280-2000-700000
22	3280-2200-700000
24	3280-2400-700000

### Static Dissipative Urethane Hose, Clear

Ø in.	Part No.
3	3279-0300
4	3279-0400
5	3279-0500
6	3279-0600
8	3279-0800
10	3279-1000
12	3279-1200

All hose products are standard QF thicknesses



- Stainless Steel Only

### Hose Clamp

Ø in.	Part No.
2	3285-0200
3	3285-0300
4	3285-0400
5	3285-0500
6	3285-0600
7	3285-0700
8	3285-0800
9	3285-0900
10	3285-1000
12	3285-1200
14	3285-1400
16	3285-1600
18	3285-1800
20	3285-2000
22	3285-2200
24	3285-2400

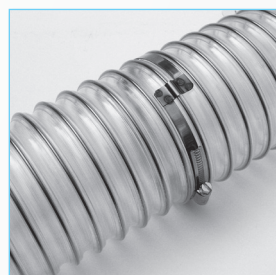

- Conforms to hose's wire helix for more secure fit.

### Bridge Hose Clamp

Ø in.	Part No.
2	3288-0200
2.5	3288-0250
3	3288-0300
4	3288-0400
5	3288-0500
6	3288-0600
7	3288-0700
8	3288-0800
10	3288-1000
12	3288-1200



HOSES & CLAMPS





### Rigid Flex Steel Hose

Ø in.	Part No.
1.5	3281-1500
2	3281-0200
2.5	3281-2500
3	3281-0300
3.5	3281-3500
4	3281-0400
5	3281-0500
5.5	3281-5500
6	3281-0600
7	3281-0700
8	3281-0800
9	3281-0900
10	3281-1000
12	3281-1200
14	3281-1400

- Flexible rigid steel hose for higher temperature or abrasive material.
- Available in Galvanized or Stainless Steel.
- 1.5" - 6" is sold in 5' increments of up to a 25' maximum length.
- 7" - 14" hoses are sold in 5' increments only. If lengths longer than 5' are needed, Nordfab can supply 5' hose assemblies with Quick-Fit ends to easily connect additional assemblies.
- Comes with raw ends standard.
- QF or Angle Flange ends can be attached (additional charge).

\* Do **NOT** use #3285 SS Hose Clamps with these hoses (3281 & 3283). Alternate ends are available for these hoses upon request at additional cost.



### Ultra Flex Steel Hose

Ø in.	Part No.
3	3283-0300
4	3283-0400
5	3283-0500
6	3283-0600
7	3283-0700
8	3283-0800

- Special flex-steel hose.
- Available in Galvanized or Stainless Steel.
- 3" - 6" is sold in 5' increments of up to a 25' maximum length.
- 7" - 8" hoses are sold in 5' increments only. If lengths longer than 5' are needed, Nordfab can supply 5' hose assemblies with Quick-Fit ends to easily connect additional assemblies.
- Comes with raw ends standard.
- QF or Angle Flange ends can be attached (additional charge).

All hose products are standard QF thicknesses

## FLEX HOSE STYLES

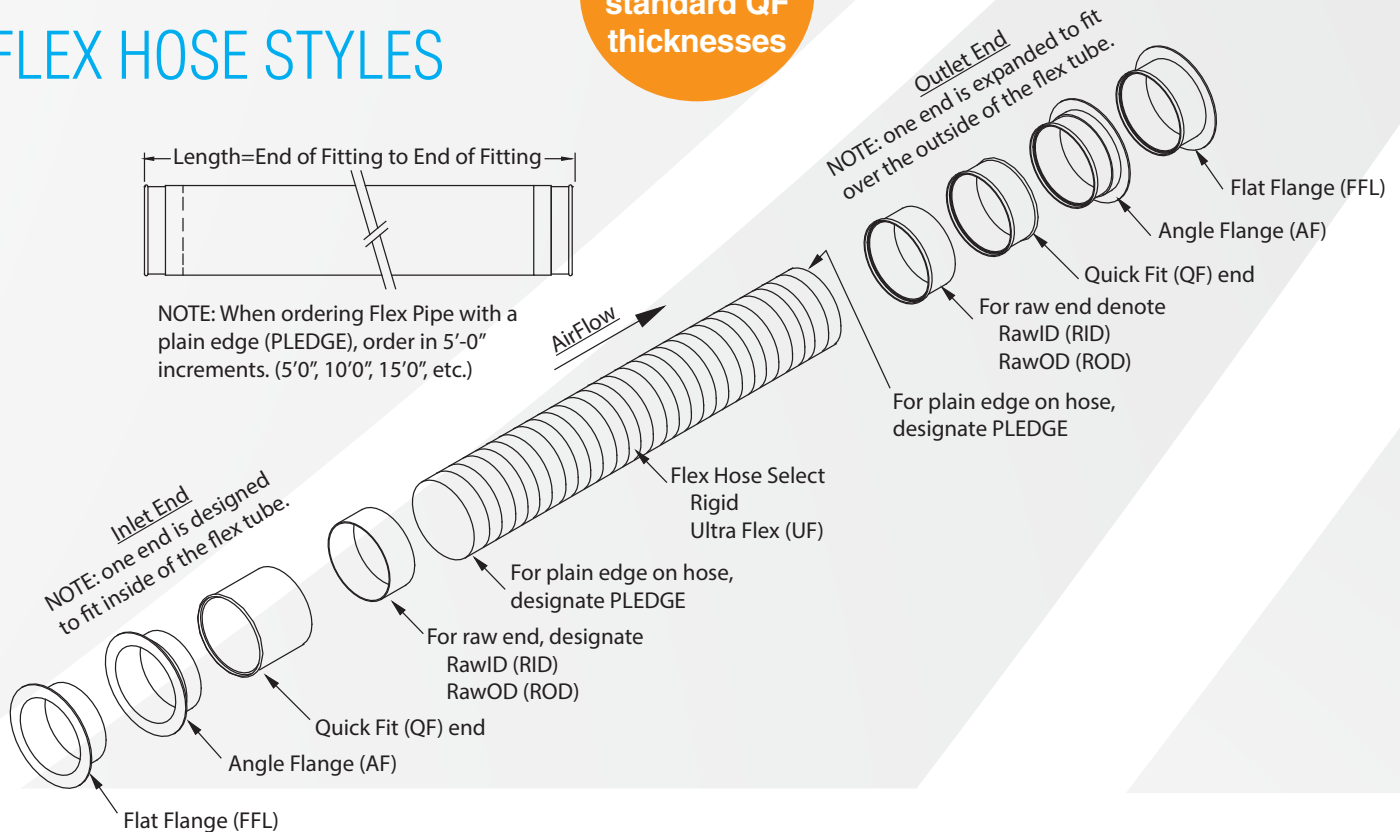

HOSES & CLAMPS





- High efficiency, economical method of diverting flow of material or air.
- Constructed of heavy 3/16" thick and painted black metal with welded seams. Transition available in 14ga or 12ga (flanged only).
- Supplied with heavy duty flange bearings and rubber seal in door.
- Manual Open and Close.
- 45° angle only.
- Other sizes available upon request.

### XD Manual Diverter Valve

Ø in	QF Manual Diverter Valve 4235-XX45-100000	XD-ANGFL Manual Diverter Valve 4235-XX45-100000	XD-ANGFL Manual Diverter Valve 2235-XX45-100000
8	•	•	•
9	•	•	•
10	•	•	•
11	•	•	•
12	•	•	•
13	•	•	•
14	•	•	•
15	•	•	•
16	•	•	•
17	•	•	•
18	•	•	•
20	•	•	•
22	•	•	•
24	•	•	•

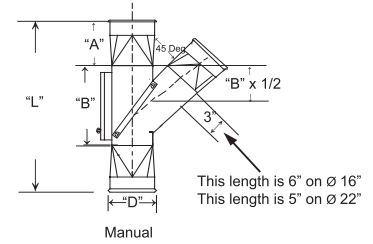

- High efficiency, economical method of diverting flow of material or air.
- Constructed of heavy 3/16" thick and painted black metal with welded seams. Transition available in 14ga or 12ga (flanged only).
- Supplied with heavy duty flange bearings and rubber seal in door.
- Power Open and Close.
- Minimum 75psi.
- 45° angle only.
- Other sizes available upon request.
- Solenoid has plastic housing. Bearing is iron.

### XD Automatic Diverter Valve

Ø in	QF Automatic Diverter Valve 4236-XX45-100000	XD-ANGFL Auto Diverter Valve 4236-XX45-100000	XD-ANGFL Auto Diverter Valve 2236-XX45-100000
8	•	•	•
9	•	•	•
10	•	•	•
11	•	•	•
12	•	•	•
13	•	•	•
14	•	•	•
15	•	•	•
16	•	•	•
17	•	•	•
18	•	•	•
20	•	•	•
22	•	•	•
24	•	•	•

DIVERTER VALVES

### Reed Switch Assembly 2.50

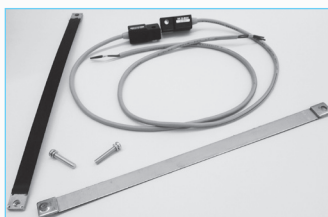

**Part No.**

3203-0000-RSW250



Cylinder with reed switches attached shown at left

- **Optional** position (open/closed) sensing switch with indicator light.
- Assembly includes two switches, one indicating open position and one indicating closed position.
- Applies to both styles of automatic Diverter Valves.

All cylinders are magnetic



### XD No-Loss Stackhead

Ø in	XD-QF No-Loss Stackhead, 14ga 4204-XX00-100000	XD-ANGFL No-Loss Stackhead, 14ga 4204-XX00-100000	XD-ANGFL No-Loss Stackhead, 12ga 2204-XX00-100000
8	•	•	•
9	•	•	•
10	•	•	•
11	•	•	•
12	•	•	•
13	•	•	•
14	•	•	•
15	•	•	•
16	•	•	•
17	•	•	•
18	•	•	•
20	•	•	•
22	•	•	•
24	•	•	•
26	•	•	•
28	•	•	•
30	•	•	•
32	•	•	•
34	•	•	•
36	•	•	•
38	•	•	•
40	•	•	•

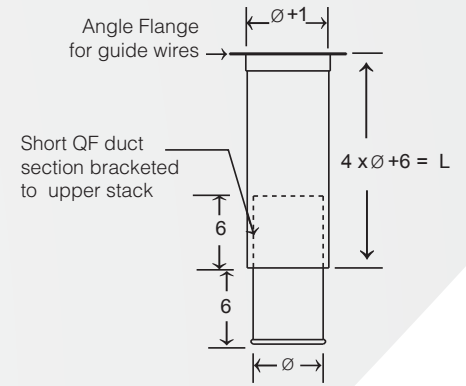

- Used when exhausting from fans or stacks through roof.
- Eliminates back pressure on fan while providing weather protection.
- Flange for guide wire attachment.



### XD Jet Cap

Ø in	XD-QF Jet Cap, 14ga 4258-XX00-100000	XD-ANGFL Jet Cap, 14ga 4258-XX00-100000	XD-ANGFL Jet Cap, 12ga 2258-XX00-100000
8	•	•	•
10	•	•	•
12	•	•	•
13	•	•	•
14	•	•	•
15	•	•	•
16	•	•	•
17	•	•	•
18	•	•	•
20	•	•	•
22	•	•	•
24	•	•	•
26	•	•	•
28	•	•	•
30	•	•	•
32	•	•	•
34	•	•	•
36	•	•	•
38	•	•	•
40	•	•	•

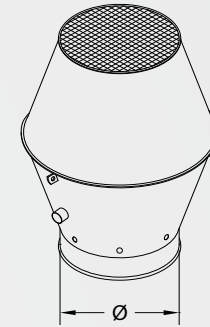

- Prevents rain from entering ducting.
- Inner funnel piece allows rain to drain out of ductwork even when system is not running.
- Has three angle brackets for guide wire attachment.

ACCESSORIES

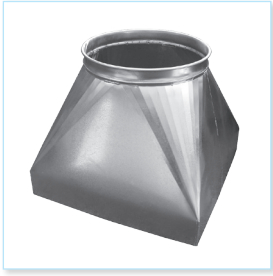

## Canopy Hood

Ø in	Part No.	Square Opening
8 - 18	X270-XXXX	To match your specifications

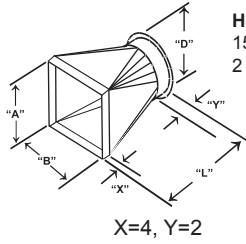

**Hood Design Basis:**  
 150 fpm capture velocity  
 2 ft. distance from source

- Specify opening size. Hemmed end.
- Maximum rectangular size 72"x48".
- If flange needed, please see Transition.

## Reducer Styles

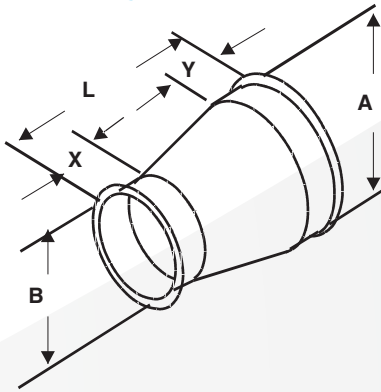

QF STYLE

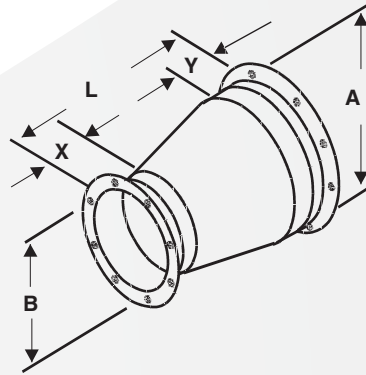

ANGLE FLANGED STYLE

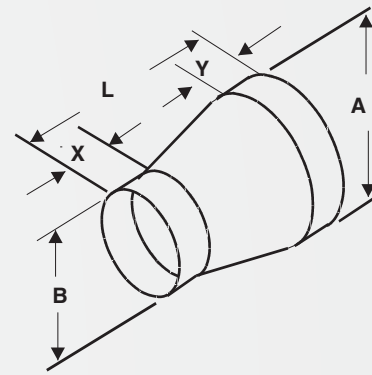

RAW END STYLE

Reducers are produced by the following formula:

$$\text{QF LENGTH} = (A-B) + 6'' \quad [7'' \text{ MIN}]$$

$$\text{Flanged LENGTH} = (A-B) + 8'' \quad [9'' \text{ MIN}]$$

NOTE: Any combination of the above styles are available upon request. Please specify all the required dimensions and all reducer end configurations (Raw ID, Raw OD, QF, Flange, etc.).

Item#	Qty	A	Style QF Flange Raw	B	Style QF Flange Raw	L (A-B+6)	X STD-2"	Y STD-2"	Part Gauge	Flange Material	Flange Dwg	Special Notes

## Branch Styles

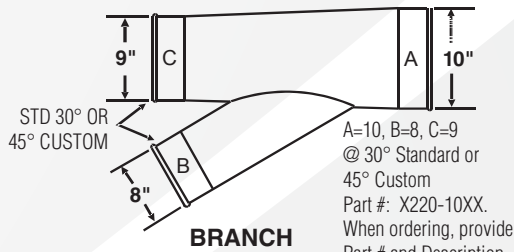

A=10, B=8, C=9  
@ 30° Standard or  
45° Custom  
Part #: X220-10XX.  
When ordering, provide  
Part # and Description.  
Examples:  
X220-10 10-8-9  
or Branch 10-8-9  
X220-10 10-8-9 @ 45°  
or Branch 10-8-9 @ 45°

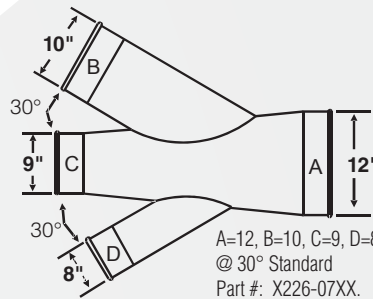

A=12, B=10, C=9, D=8  
@ 30° Standard  
Part #: X226-07XX.  
When ordering, provide  
Part # and Description.  
Examples:  
X226-12 12-10-9-8  
or Double Branch 12-10-9-8  
X226-07 12-10-9-8 @ 45°  
Double Branch 12-10-9-8 @ 45°

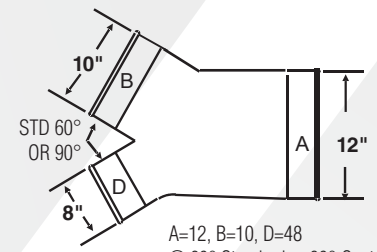

A=12, B=10, D=8  
@ 60° Standard or 90° Custom  
Part #: X221-12XX.  
When ordering, provide  
Part # and Description.  
Examples:  
X221-12 12-10-8  
or Y-Branch 12-10-8  
X221-12 12-10-8 @ 90°  
or Y-Branch 12-10-8 @ 90°

# Transition Styles

**Transition Rectangular to Round**

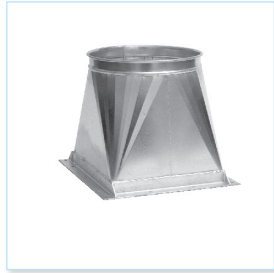

**Transition Square to Square**

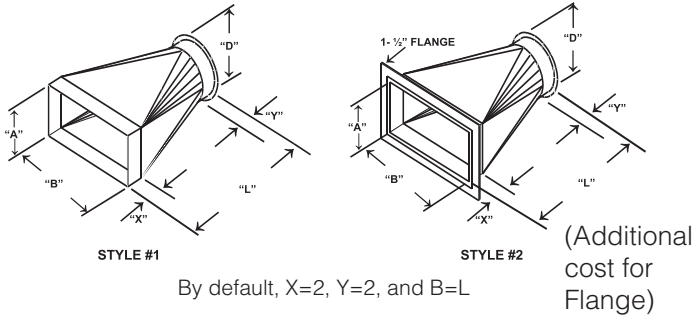
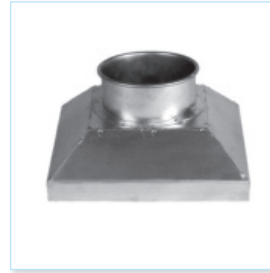

- L must be at least 75% of B or it will be Square to Square.
- L of Square to Round (at least 7" minimum, larger in some instances).  
L of Square to Square (4" minimum).

Built to your specifications. Please list all required dimensions and details.

Specify Rectangle End:     Flanged     Raw End I.D.     Raw End O.D.

Flange Type:     Angle Bar     Flat Bar     Sheet Metal

Specify Round End:     QF     Flanged     Hose Conn.     Raw I.D. Or O.D.

NOTE: If no hole pattern is supplied for flanges, they will be supplied blank to be field drilled.  
L = to the greater of B or D.

Item #	Qty.	D	A	B	X Std 2"	Y Std 2"	L	Gauge	Flange Material	Flange Dwg	Special Notes

Specify dimensions A, B, D, and L. Also available with flanged connections. Specify flange pattern. If no hole pattern is supplied for flanges, they will be supplied blank to be field drilled.

Standard flange material is 1-1/2 x 3/16" THK angle. Diameter sizes exceeding 24" will be supplied with a flange. Standard length is equal to B dimension, unless otherwise specified. Prices are determined by the rectangular dimension of style 1. Add for Flange on style 2.

NOTE: Square to square transitions are made when the customer's specified length is less than 75% of the B dimension.

## Nordfab Drawing Service

- Provide Nordfab with basic information about the job:
- Material conveyed
  - Machine type and placement
  - Recommended velocity

**PART NO.**

DS/MC | Drawings priced by machine connection

And Nordfab will provide you with an AutoCAD or PDF file of the drawing, complete with a list of the XD parts set forth in the drawing.





# XD Parts Take-off Worksheet

Your name \_\_\_\_\_ Email \_\_\_\_\_ Page \_\_\_\_ of \_\_\_\_  
 Company \_\_\_\_\_ Phone \_\_\_\_\_ Project \_\_\_\_\_ Date \_\_\_\_\_

Ø in	Elbows				Blast Gates	Machine Adapters	Angle Flange Adapters	QF Clamps	Flex Hose Clamps	Flex Hose Adapters	Reducers, Transitions, etc.	Branches, Double Branches, Y-Branches			Qty
	90°	60°	45°	30°								A	B	C	
8															
9															
10															
11															
12															
13															
14															
15															
16															
17															
18															
20															
22															
24															
26															
28															
30															
32															
34															
36															
38															
40															



# SIZING A QF PIPE SYSTEM

Nordfab offers assistance to those salespeople and customers who have never designed a piping system. We can assist you in determining the correct pipe size and configuration that will supply you with the correct flow. Please call an Inside Sales Representative for assistance.

EXAMPLE: Always work from your machines back toward the filter. Suppose that you have a 5" drop that rises and runs back to join with a 6" drop as sketched above. What size branch will you need?

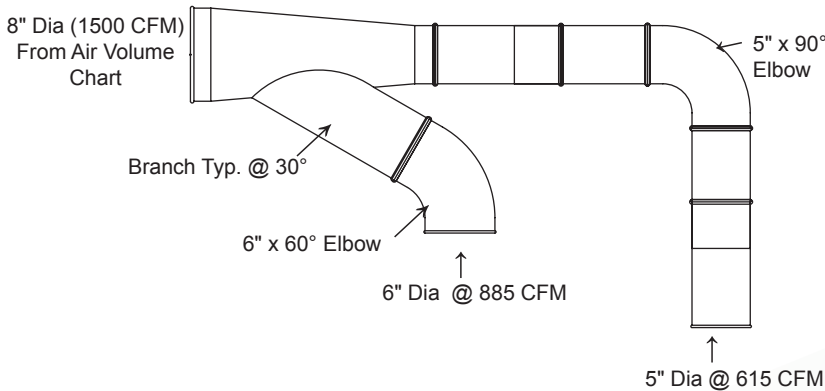
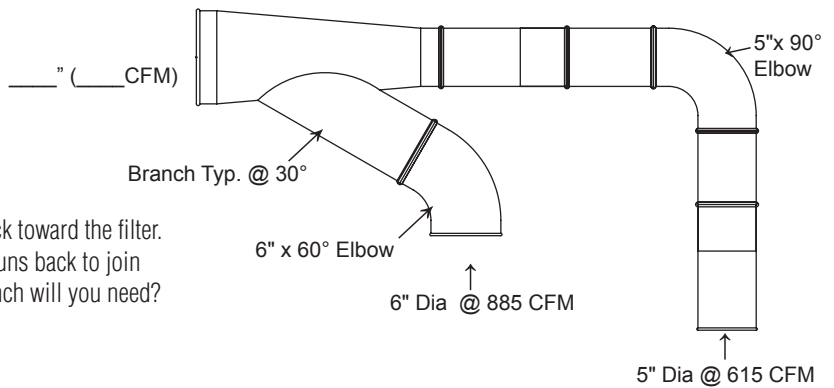

The 5" pipe carries 615 CFM at 4500 FPM, (See chart). The 6" pipe will need 885 CFM at the same velocity (see chart). Added together, you have a total of (615 + 885) 1500 CFM coming together.

Looking again at the chart under 4500 FPM, you find that 1500 CFM is not listed, but falls very close to the 1570 CFM listed for an 8" pipe. This indicates that the 5" joined to the 6" will require an 8" pipe to carry all of the material at the right velocity. The branch, therefore, will be 8" on the downstream end reducing down to a 5" with a 6" branching off of it. That is listed as an 8-6-5 branch.

## USING THE CFM/FPM CHART

This chart allows you to choose the correct pipe size for the CFM that is required. Different materials need to be conveyed at different velocities to prevent the material from falling out of the air stream.

For example, wood chips and saw dust flow well at 4500 feet per minute. Referring to the chart, a 10" pipe will convey 2455 CFM at 4500 FPM. This indicates that a 10" pick-up on a machine will use 2455 CFM from the filtering system. Or working in reverse, if you know that a machine will require approximately 2500 CFM to remove the waste, then you should design a 10" pipe for the application.

AIR VOLUME IN DUCTS IN CUBIC FEET PER MINUTE (CFM)											
VELOCITY IN FEET PER MINUTE (FPM)											
DUCT Ø	2000	2500	3000	3500	4000	4500	5000	5500	6000	6500	7000
8	700	875	1050	1220	1395	1570	1745	1920	2095	2270	2445
9	885	1105	1325	1545	1765	1990	2210	2430	2650	2870	3090
10	1090	1365	1635	1910	2180	2455	2725	3000	3270	3545	3820
11	1320	1650	1980	2310	2640	2970	3300	3630	3960	4290	4620
12	1570	1965	2355	2750	3140	3535	3925	4320	4710	5105	5500
13	1850	2300	2770	3225	3685	4150	4610	5070	5530	5990	6450
14	2140	2675	3205	3740	4275	4810	5345	5880	6415	6950	7485
15	2450	3070	3680	4300	4900	5520	6130	6750	7360	7970	8590
16	2790	3490	4190	4885	5585	6285	6980	7680	8380	9075	9775
17	3150	3940	4730	5515	6300	7090	7880	8670	9450	10240	11030
18	3535	4420	5300	6185	7070	7950	8835	9720	10600	11485	12370
20	4365	5455	6545	7635	8725	9815	10910	12000	13090	14180	15270
22	5280	6600	7920	9240	10560	11880	13200	14520	15840	17160	18480
24	6285	7855	9425	10995	12656	14135	15710	17280	18850	20420	21995
26	7370	9210	11055	12900	14740	16580	18420	20270	22110	23950	25800
28	8550	10685	12820	14960	17100	19230	21310	23500	25650	27780	29920
30	9800	12260	14700	17170	19625	22080	24530	26990	29440	31890	34350
32	11160	13950	16750	19541	22330	25120	27910	30700	33490	36302	39070
34	12600	15755	18905	22055	25210	28360	31510	34660	37810	40965	44115
36	14130	17665	21195	24730	28260	31800	35325	38860	42390	45925	49455
38	15745	19680	23615	27550	31490	35425	39360	43295	47230	51170	55100
40	17445	21800	26170	30530	34890	39250	43610	47975	52330	56700	61055



# XD PRODUCTS CONDITIONS OF SALE

## General Conditions of Sale

The Terms and Conditions of acceptance of sale as set forth herein, Nordfab, LLC (Nordfab's Order Acknowledgment and all drawings, specifications, and descriptions, if any, and any other documents attached hereto or transmitted herewith and incorporated herein by reference, constitute the entire agreement between Nordfab and the Buyer (hereinafter "the Agreement"). Nordfab's acceptance of Buyer's order is expressly conditioned upon Buyer's consent to the Terms and Conditions set forth herein. In no event shall any conflicting or different terms in Buyer's order become part of this Agreement unless Nordfab explicitly agrees to such in writing or expressly incorporates such terms into this Agreement. The failure of Nordfab to object to any provision in conflict with these Terms and Conditions whether contained in Buyer's purchase order or otherwise, shall not be construed as a waiver of the provisions of the Agreement or the Terms and Conditions contained herein nor as an acceptance thereof. Any prior oral or written statements or proposals provided by Nordfab are preliminary only unless otherwise agreed and confirmed in writing. If any of the terms and conditions contained in any prior oral or written statements or proposals by Nordfab conflict with these General Terms and Conditions of Sale, these General Terms and Conditions of Sale shall prevail.

This Agreement is deemed to be executed and performed in the State of North Carolina, and shall be governed, construed, and enforced in accordance with the laws of the State of North Carolina, excluding that State's conflict of law principles, as to all matters arising out of or relating to this Agreement. Nordfab and the Buyer exclude the application of the 1980 United Nations Convention on Contracts for the International Sale of Goods if otherwise applicable. In the event of any controversy, claim, or dispute between Nordfab and Buyer arising out of or relating to this Agreement, such controversy, claim, or dispute shall be tried exclusively in the General Court of Justice, Superior Court Division for the State of North Carolina with venue being in Davidson County, North Carolina. If any provision of this Agreement is held to be illegal, invalid or otherwise unenforceable in a judicial proceeding, then such provision shall be severed and shall be inoperative provided that the fundamental terms and conditions of this Agreement remain legal and enforceable, the remainder of this Agreement shall remain operative and binding on Nordfab and Buyer.

## Limited Warranty

Nordfab warrants that the products sold hereunder conform to any applicable drawings and specifications attached hereto and will be free from any defects in material and workmanship which become apparent under normal use. This limited warranty applies to the original Buyer only and is non-transferrable. To make a claim under this limited warranty, Buyer must give written notice to Nordfab within a period of 12 months from the date of installation or 12 months from the date of shipment, whichever period first expires. If, within that period, Nordfab receives from Buyer written notice of any alleged defect in or non-conformance of any product covered by this limited warranty and if, in Nordfab's sole judgment, the product does not conform with this limited warranty, then Buyer shall, at Nordfab's request, return the part or product F.O.B. Nordfab's shipping point. Nordfab, at its sole option and expense, shall then repair or replace the defective part or product or repay Buyer the full price paid for such part or product. Dismounting of defective or nonconforming parts and remounting of any repaired or replaced parts is at Buyer's sole expense. This Limited Warranty, as it relates to the delivery of spare parts or replacement for non-conforming parts, expires when the limited warranty for the original product or equipment expires. Any repayment of purchase price shall be without interest. NORDFAB'S SOLE RESPONSIBILITY, AND BUYER'S EXCLUSIVE REMEDY HEREUNDER, SHALL BE LIMITED TO SUCH REPAIR, REPLACEMENT, OR REPAYMENT OF THE PURCHASE PRICE AS ABOVE PROVIDED. NO OTHER WARRANTIES, EXPRESS, STATUTORY, OR IMPLIED, ARE MADE AND ANY AND ALL IMPLIED WARRANTIES OF MERCHANTABILITY, QUALITY, OR FITNESS FOR PARTICULAR PURPOSE ARE EXPRESSLY DISCLAIMED. This limited warranty does not cover and Nordfab makes no warranty with respect to:

- A) failures not reported to Nordfab within the warranty period specified above;
- B) failure or damage due to misapplication, abuse, improper installation or abnormal conditions of any kind, including, but not limited to, temperature, dirt or other corrosive matter;
- C) failures due to operation, either intentional or otherwise, above rated capacities or in an otherwise improper manner;
- D) products which have been in any way tampered with or altered by anyone other than an authorized representative of Nordfab;
- E) products damaged in shipment or otherwise without fault of Nordfab;
- F) expenses incurred by Buyer in an attempt to repair, rework, or replace any alleged defective product; and
- G) defects in material and workmanship which are attributable to drawings and specifications provided by Buyer.

## Terms of Payment

Unless agreed to in writing by Nordfab's Sales Manager, the terms of this Agreement are NET 30. If the full purchase price is not paid by Buyer NET 30, then interest shall accrue at the rate of 1.5% per month. Buyer agrees that if Nordfab is required to bring suit to collect any sums due Nordfab under this Agreement, then Buyer shall be responsible for all costs and expenses incurred by Nordfab, including but not limited to Nordfab's reasonable attorney's fees.

## Claims for Shortages

Any claims for loss, breakage (obvious or concealed), or shortage are Buyer's sole responsibility and should be made to the carrier immediately. Nordfab will render Buyer reasonable assistance in securing satisfactory adjustment of such claims. Any notice of shortages or other errors must be made in writing to Nordfab within 15 days after receipt of shipment. Failure to give such notice shall constitute unqualified acceptance of the product and a waiver by Buyer of all claims against Nordfab for loss, breakage or shortage. Risk of loss for damage to products sold under this Agreement passes to Buyer when the carrier takes custody of any of the products purchased under this Agreement regardless of who pays shipping costs.

## Buyer Responsibility

Nordfab products are sold as components only.

Nordfab products are manufactured to meet the customer's designed solution for dust extraction. Air flow equipment design and performance is the responsibility of the customer.

No installation is included. It is the customer's responsibility to ensure that the hanging method is based on the proper load calculations per regional codes and regulations.

## Limitation of Liability

Nordfab's sole responsibility and Buyer's sole and exclusive remedy with respect to any alleged breach of the limited warranty, as set forth above, or any other claim under this Agreement shall be limited to repair, replacement or repayment of the purchase price at Nordfab's sole discretion. Nordfab's total responsibility for any and all claims, damages of any nature, losses, liabilities or costs of corrective efforts, including, but not limited to, those relating to any limited warranty or claim arising out of or related to performance of this Agreement or the products covered hereunder or the performance thereof shall not exceed the total purchase price of the product(s) covered by this Agreement. IN NO EVENT SHALL NORDFAB BE LIABLE FOR ANY SPECIAL, INDIRECT, INCIDENTAL, OR CONSEQUENTIAL DAMAGES OF ANY CHARACTER; INCLUDING, BUT NOT LIMITED TO, LOSS OF USE OF PRODUCTION FACILITIES OR EQUIPMENT, LOST PROFITS, PROPERTY DAMAGE, EXPENSE INCURRED IN RELIANCE ON NORDFAB'S PERFORMANCE HEREUNDER, OR LOST PRODUCTION, WHETHER SUFFERED BY BUYER OR ANY THIRD PARTY. Nordfab specifically disclaims all liability for any and all costs, claims, demands, charges, expenses or other damages, either direct or indirect, incident to all property damages arising out of any cause of action based on strict liability.